

Note:

1. Min. vertical failing load: 70kN;
2. Min. slip load: 14%RTS of OPGW;
3. Hot-dip galvanized to ISO 1461;
4. All dimensions are in millimeters;
5. The diameter and RTS of OPGW: 14.60mm, 68.9kN;
6. The stranding direction of OPGW outer layer is right hand;
7. Version numbers may be supplemented to our products' models.

7	Earth Bonding Lead	JDX-95-2000BBA	Aluminum	1	
6	Structural Reinforcing Rods	OCN	Al.-Clad Steel	1	
5	Outer Rods	OCW	Aluminum Alloy	1	
4	Elastomer Insert	XJ-10	EPDM	1	
3	Cast Aluminium Clamp	TK-10	Aluminum Alloy	1	70kN
2	Strap	PD-10300	Galv. Steel	1	100kN
1	Hanger	UB-2090	Galv. Steel	1	120kN
Item	Description	Cat. No.	Material	QTY	U.T.S

General Tolerance		
<=30	±1.5mm	ANGLE: ±
>30	±5%	
Weight	±15%	
Drawing	Alex	2020-01-29
Checked	Jeff	2020-01-29
Approved	Felix	2020-01-29

Suspension Set for OPGW
TYPE: OC-0500-1460

Jiangsu Zhongtian
Technology Co., Ltd.



Mass		Scale	NTS
JSF-105653-3	REV		B

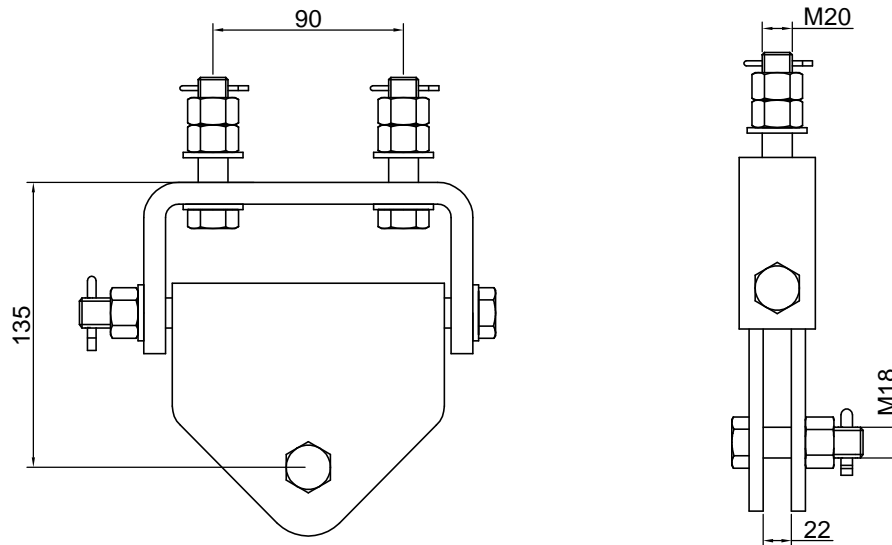

Note:

1. Material: Galvanized steel, the cotter-pin is stainless steel;
2. Galvanized to ISO 1461;
3. Minimum failing load: 120kN;
4. All dimensions are in millimetres.

General Tolerance			Hanger UB-2090	 ZTT 中天科技			
<=30	±1.5mm	ANGLE:					
>30	±5%	±					
Weight	±15%						
Drawing	Alex	2020-01-29	Jiangsu Zhongtian Technology Co., Ltd.	Mass		Scale	NTS
Checked	Jeff	2020-01-29		JSF-122007	REV	A	
Approved	Felix	2020-01-29					

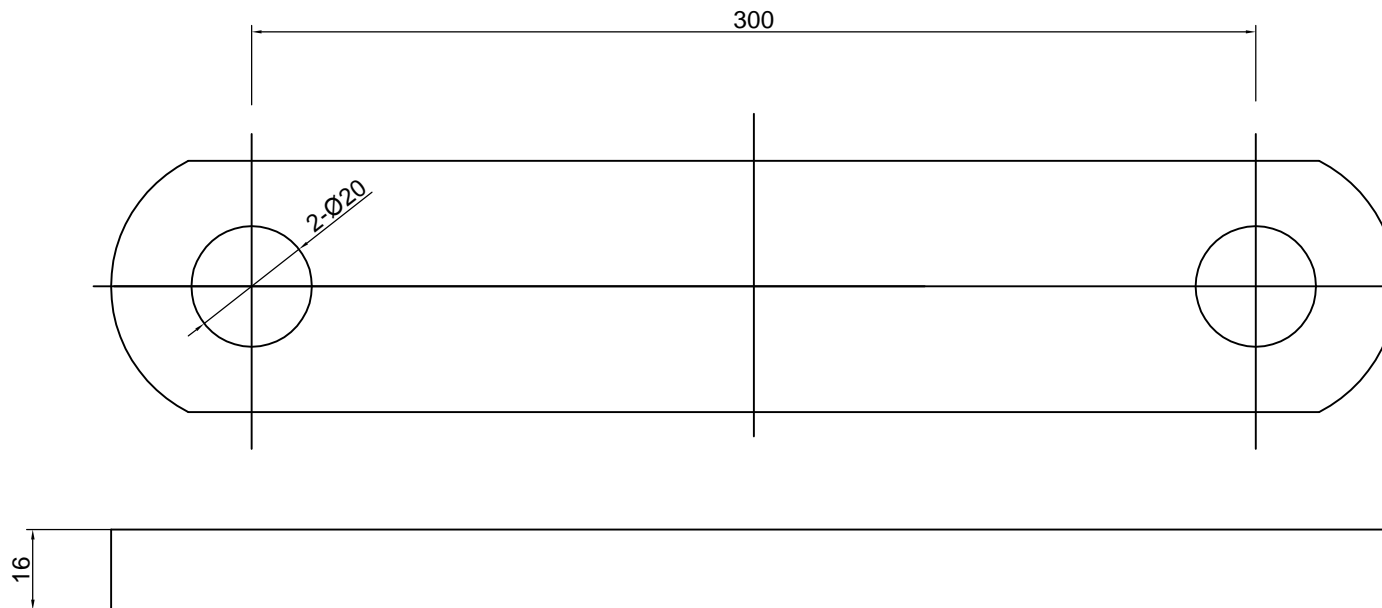

Note:

1. Material: Galvanized steel;
2. Galvanized to ISO 1461;
3. Minimum failing load: 100kN;
4. All dimensions are in millimetres.

General Tolerance			Strap TYPE:PD-10300				
<=30	±1.5mm	ANGLE:					
>30	±5%	±					
Weight	±15%						
Drawing	Alex	2020-01-29	Jiangsu Zhongtian Technology Co., Ltd.	Mass		Scale	NTS
Checked	Jeff	2020-01-29		JSF-131006	REV	A	
Approved	Felix	2020-01-29					

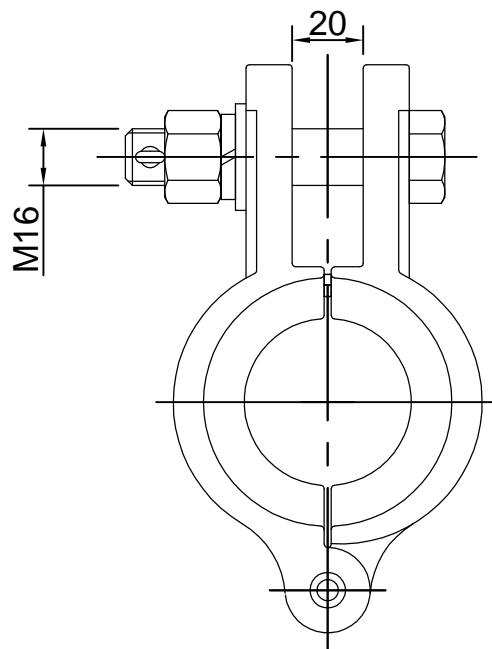
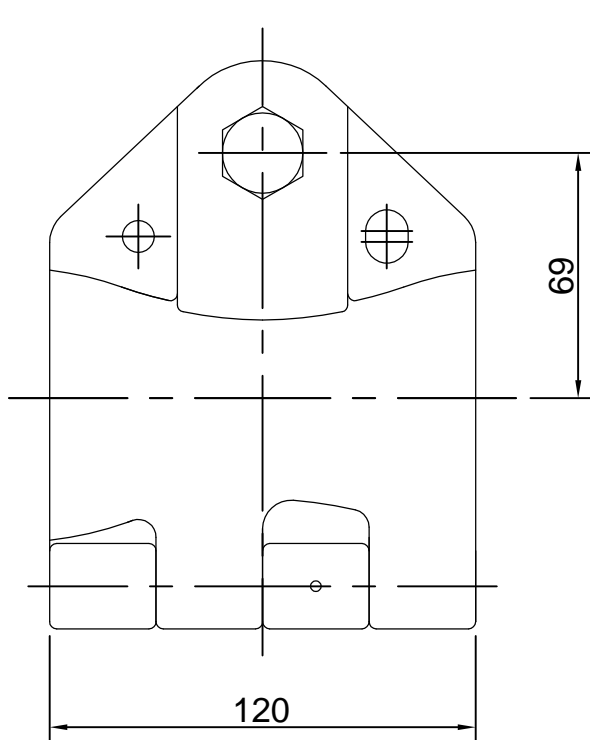

Note:

1. Material: The clamp body is aluminium alloy, the cotter pin & limit pin are stainless steel, the other parts are galvanized steel;
2. All ferrous parts are hot-dip galvanized as per ISO 1461 ;
3. Minimum failing load: 70kN;
4. All dimensions are in millimetres;
5. Version numbers may be supplemented to our products' models.

General Tolerance			Cast Aluminium Clamp TYPE: TK-10							
<=30	±1.5mm	ANGLE: ±					Jiangsu Zhongtian Technology Co., Ltd.	Mass(kg)	Scale	NTS
>30	±5%									
Weight	±15%		JSH-122004	REV	A					
Drawing	Alex	2020-01-29								
Checked	Jeff	2020-01-29								
Approved	Felix	2020-01-29								

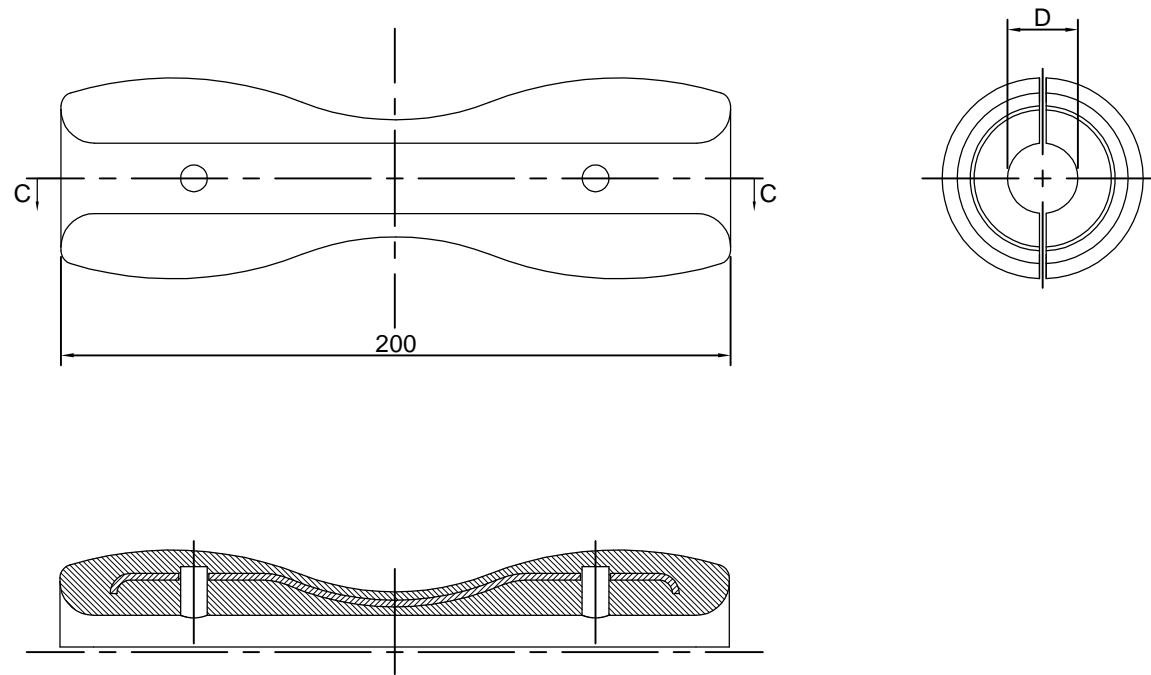

Section C-C

Note:

1. Material: EPDM;
2. All dimensions are in millimetres;
3. Version numbers may be supplemented to our products' models.

General Tolerance			Elastometer Insert clamp TYPE: XJ-10				
<=30	±1.5mm	ANGLE: ±					
>30	±5%						
Weight	±15%						
Drawing	Alex	2020-01-29	Jiangsu Zhongtian Technology Co., Ltd.	Mass		Scale	NTS
Checked	Jeff	2020-01-29		JSH-122010	REV	A	
Approved	Felix	2020-01-29					

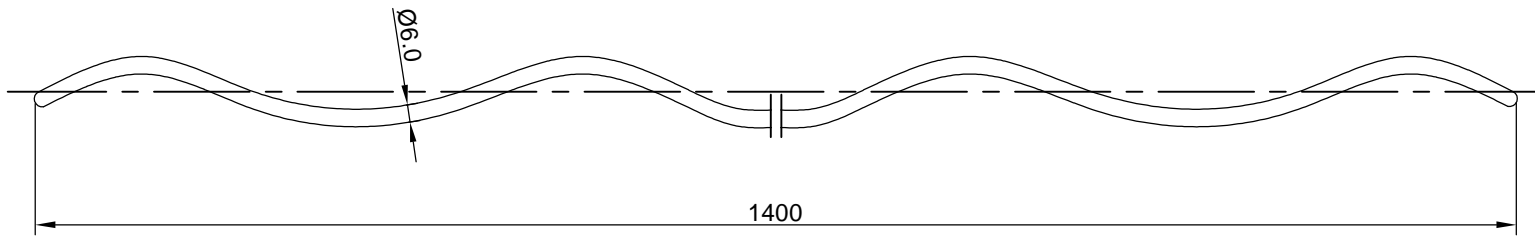

Note:

1. Material: Aluminium alloy;
2. Rod diameter: 6.0mm;
3. All dimensions are in millimeters;
4. Version numbers may be supplemented to our products' models.

General Tolerance			Outer Rods TYPE: OCW	 ZTT 中天科技			
<=30	±1.5mm	ANGLE:					
>30	±5%	±					
Weight	±15%						
Drawing	Alex	2020-01-29	Jiangsu Zhongtian Technology Co., Ltd.	Mass		Scale	NTS
Checked	Jeff	2020-01-29		JSF-105653-9	REV	A	
Approved	Felix	2020-01-29					

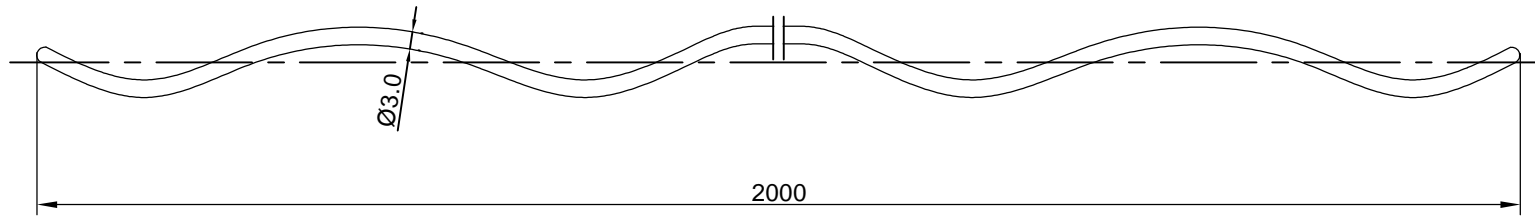

Note:

1. Material: Aluminium clad steel;
2. Rod diameter: 3.0mm;
3. All dimensions are in millimeters;
4. Version numbers may be supplemented to our products' models.

General Tolerance			Structural Reinforcing Rods TYPE: OCN	 ZTT 中天科技		
<=30	±1.5mm	ANGLE:				Jiangsu Zhongtian Technology Co., Ltd.
>30	±5%	±	JSF-105653-10	REV	A	
Weight	±15%					
Drawing	Alex	2020-01-29				
Checked	Jeff	2020-01-29				
Approved	Felix	2020-01-29				

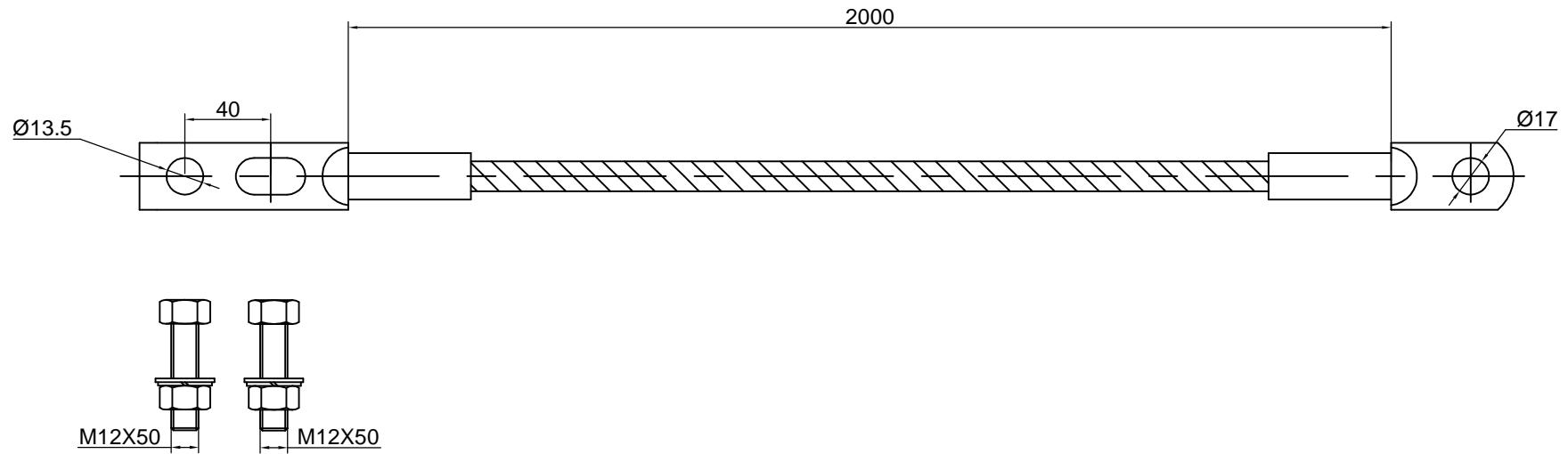

Note:

1. Material: Aluminium, the bolt assembly is galvanized steel;
2. All dimensions are in millimeters;
3. Version numbers may be supplemented to our products' models.

General Tolerance			Earth Bonding Lead TYPE:JDX-95-2000BBA	 ZTT 中天科技		
<=30	±1.5mm	ANGLE:				
>30	±5%	±				
Weight	±15%		Mass		Scale	NTS
Drawing	Alex	2020-01-29	Jiangsu Zhongtian Technology Co., Ltd.	JSF-138048	REV	A
Checked	Jeff	2020-01-29				
Approved	Felix	2020-01-29				